

AGENDA
RAYTOWN PARKS & RECREATION BOARD
Monday, June 16, 2025 7:00 PM

Hosted in person at the Raytown City Hall:
10000 E 59th ST, Raytown MO 64133

Or via Zoom Link:

<https://us02web.zoom.us/j/83906362474?pwd=KT2Pboc6WalbCNCbziHJSGjceQllje.1>

I. Call to Order

II. Public Participation

Approval of Minutes –May 19th, 2025

III. Reports of Officers

President – Robbie Tubbs

Vice President – Brian Morris

IV. Reports of Standing & Special Committees

Personnel – Jourdan Price

Finance – Melina Alford

Program – Brian Morris

Buildings & Grounds – Dave Thurman

Main Street- Robbie Tubbs

V. Staff Reports

Director – Dave Turner

Superintendent of Parks – Tony Mesa

Recreation- Matt Hartmann

VI. New Business

1. FY25/26 Capital Budget expenses
2. FIFA parking/traffic control
3. Board elections for President and Vice President

VII. Other Business

VIII. Announcements

IX. Adjourn

- Next regular Meeting: July 21st, 7 PM at Raytown Parks office, election for President and Vice President.

**Raytown Park Board
Minutes
May 19, 2025**

Attendance:

Park Board: Robbie Tubbs and Brian Morris attended in person and Zoom- Dave Thurman, Jules Sneddon, Jourdan Price, Angel Abercrombie and Brent Hugh.

Staff: Dave Turner, Tony Mesa, Matt Hartmann and Jonda DeMarco

Guests: Zoom- Carla Coldwell, Christy Sewing and Alderman Loretha Hayden.

A quorum was declared present, and the meeting was called to order at 7:01pm. Brian Morris made a motion to approve the minutes from April 21, 2025. Angel Abercrombie seconded, and the motion passed.

Reports of Officers:

President- Robbie attended the Get Outdoor Day, and complimented staff on an excellent job. She also attended the first Raytown Live of the season.

Vice President -Brian commented on the work at Terry Copeland Park-benches, signs and trash bins.

Reports of Standing & Special Committees:

Personnel – no report

Finance – no report

Program – no report

Buildings & Grounds – no report

Main Street – no report

Staff Reports:

Director – a written report was distributed

Superintendent of Parks – a written report was distributed

Recreation – a written report was distributed

New Business:

1. Brian Morris made a motion to proceed with applying for variance on the parking lot at Rice-Tremonti property. Dave Thurman seconded, and the motion passed.
2. Board discussed plans for our parks during FIFA next summer, concerns that the parking lots will be overrun with out of town guest sleeping in cars and trying to camp in parks, due to our proximity of the stadium.
3. Dave Turner discussed submitting 25/26 budget as a normal year, if sales tax pass we can discuss how to use funds at that point.
4. Brian Morris made a motion to adjourn at 8:39pm. Jourdan Price seconded, and the motion passed.

Please note: June meeting will be on June 16, 2025



Budget Report Account Summary

For Fiscal: 2024-2025 Period Ending: 06/30/2025

		Original Total Budget	Current Total Budget	Period Activity	Fiscal Activity	Variance Favorable (Unfavorable)	Percent Remaining
Fund: 201 - PARKS & RECREATION							
Revenue							
<u>201-00-00-100-41305</u>	Parks/Storm Water Capital Sales Ta	362,000.00	362,000.00	0.00	212,610.20	-149,389.80	41.27 %
<u>201-00-00-100-46102</u>	Investment Income	17,000.00	17,000.00	0.00	15,571.81	-1,428.19	8.40 %
<u>201-00-00-100-46401</u>	Miscellaneous Revenue	0.00	0.00	0.00	2,250.00	2,250.00	0.00 %
<u>201-92-00-000-42122</u>	Credit Card Processing Fee	1,000.00	1,000.00	42.95	701.51	-298.49	29.85 %
<u>201-92-00-100-41101</u>	Real Estate Tax	558,771.00	558,771.00	0.00	502,695.84	-56,075.16	10.04 %
<u>201-92-00-100-41102</u>	Personal Property Tax	101,057.00	101,057.00	0.00	81,601.16	-19,455.84	19.25 %
<u>201-92-00-100-41104</u>	Delinquent Real Estate Taxes	13,000.00	13,000.00	0.00	9,081.04	-3,918.96	30.15 %
<u>201-92-00-100-41105</u>	Penalties	9,900.00	9,900.00	0.00	6,493.42	-3,406.58	34.41 %
<u>201-92-00-100-41107</u>	Railroad & Utilities Tax	18,500.00	18,500.00	0.00	18,608.72	108.72	100.59 %
<u>201-92-00-100-41108</u>	Replacement Tax	30,000.00	30,000.00	0.00	35,559.46	5,559.46	118.53 %
<u>201-92-00-100-41110</u>	Circuit Breaker Refund	-700.00	-700.00	0.00	-541.62	158.38	77.37 %
<u>201-92-00-100-41111</u>	Delinquent Property Tax Revenue	9,000.00	9,000.00	0.00	8,945.80	-54.20	0.60 %
<u>201-92-00-100-46101</u>	Interest Earnings	30,000.00	30,000.00	0.00	10,609.65	-19,390.35	64.63 %
<u>201-92-00-100-46303</u>	Gain on sale of Fixed Asset	10,000.00	10,000.00	0.00	0.00	-10,000.00	100.00 %
<u>201-92-00-100-47101</u>	Ballfield Lights Fees	1,200.00	1,200.00	0.00	240.00	-960.00	80.00 %
<u>201-92-00-100-47105</u>	Shelter House Rental Fees	25,000.00	25,000.00	1,750.00	22,331.78	-2,668.22	10.67 %
<u>201-92-00-100-47110</u>	Sports Field Rental Fees	4,000.00	4,000.00	0.00	10,610.00	6,610.00	265.25 %
<u>201-92-00-100-47116</u>	Vending Machine-Kenagy	400.00	400.00	0.00	226.08	-173.92	43.48 %
<u>201-92-00-100-47204</u>	Team Sports League	20,000.00	20,000.00	0.00	3,177.00	-16,823.00	84.12 %
<u>201-92-00-100-47220</u>	Donations	11,000.00	11,000.00	0.00	10,700.00	-300.00	2.73 %
<u>201-92-00-100-47425</u>	Other Income	1,000.00	1,000.00	0.00	218.62	-781.38	78.14 %
<u>201-92-00-725-43000</u>	State Grants - TRIM	22,000.00	22,000.00	0.00	21,550.00	-450.00	2.05 %
<u>201-92-00-753-43000</u>	State Grant - LWCF	79,000.00	79,000.00	0.00	432,004.49	353,004.49	546.84 %
<u>201-92-00-754-43101</u>	Federal Grant - Omnibus (SuperSpl	1,985,000.00	1,985,000.00	0.00	0.00	-1,985,000.00	100.00 %
<u>201-92-00-755-43101</u>	Federal Grant - Omnibus (Kenagy)	980,000.00	980,000.00	0.00	0.00	-980,000.00	100.00 %
	Revenue Total:	4,288,128.00	4,288,128.00	1,792.95	1,405,244.96	-2,882,883.04	67.23%
Expense							
<u>201-00-00-100-58000</u>	BMX Appropriation	15,000.00	15,000.00	0.00	15,000.00	0.00	0.00 %
<u>201-00-00-100-59950</u>	Operating Transfer - TIF EAT's	35,000.00	35,000.00	0.00	20,336.11	14,663.89	41.90 %
<u>201-92-00-100-51102</u>	Civilian Employees	492,182.00	492,182.00	19,745.41	317,612.74	174,569.26	35.47 %
<u>201-92-00-100-51106</u>	Part Time Employees	24,099.00	24,099.00	123.75	611.88	23,487.12	97.46 %
<u>201-92-00-100-51111</u>	Civilian Employees Overtime	7,959.00	7,959.00	115.08	6,565.75	1,393.25	17.51 %
<u>201-92-00-100-51206</u>	Life Ins	1,294.00	1,294.00	0.00	753.91	540.09	41.74 %
<u>201-92-00-100-51212</u>	Deferred Compensation - 401 A	4,103.00	4,103.00	155.59	2,530.84	1,572.16	38.32 %
<u>201-92-00-100-51214</u>	Civilian Pension - LAGERS	73,309.00	73,309.00	2,820.18	42,111.93	31,197.07	42.56 %
<u>201-92-00-100-51215</u>	Health Insurance	75,033.00	75,033.00	3,192.33	49,897.32	25,135.68	33.50 %
<u>201-92-00-100-51218</u>	Med Exp - HSA contribution	7,500.00	7,500.00	0.00	4,000.00	3,500.00	46.67 %
<u>201-92-00-100-51220</u>	Dental	4,526.00	4,526.00	187.92	2,946.63	1,579.37	34.90 %
<u>201-92-00-100-51221</u>	Vision	1,058.00	1,058.00	41.97	650.17	407.83	38.55 %
<u>201-92-00-100-51225</u>	FICA	40,704.00	40,704.00	1,464.31	23,993.37	16,710.63	41.05 %
<u>201-92-00-100-51231</u>	Auto Allowance	4,980.00	4,980.00	0.00	2,275.00	2,705.00	54.32 %
<u>201-92-00-100-51238</u>	Phone Allowance	3,380.00	3,380.00	0.00	1,920.00	1,460.00	43.20 %
<u>201-92-00-100-51240</u>	Workers Compensation Insurance	34,855.59	34,855.59	0.00	20,332.41	14,523.18	41.67 %
<u>201-92-00-100-52101</u>	Office Supplies	600.00	600.00	0.00	45.67	554.33	92.39 %
<u>201-92-00-100-52122</u>	Credit Card Processing Charge	3,500.00	3,500.00	0.00	1,067.74	2,432.26	69.49 %
<u>201-92-00-100-52200</u>	Operating Supplies	3,500.00	3,500.00	0.00	844.71	2,655.29	75.87 %
<u>201-92-00-100-52233</u>	Uniforms	3,300.00	3,300.00	0.00	20.98	3,279.02	99.36 %
<u>201-92-00-100-52250</u>	Professional Services	1,400.00	1,400.00	91.00	123.80	1,276.20	91.16 %
<u>201-92-00-100-52300</u>	Repair & Maintenance Supplies	93,500.00	93,500.00	36.29	37,306.75	56,193.25	60.10 %
<u>201-92-00-100-52301</u>	Fuel	15,000.00	15,000.00	0.00	4,373.32	10,626.68	70.84 %

Budget Report

For Fiscal: 2024-2025 Period Ending: 06/30/2025

		Original	Current	Period	Fiscal	Variance	
		Total Budget	Total Budget	Activity	Activity	Favorable	Percent
						(Unfavorable)	Remaining
<u>201-92-00-100-53101</u>	Postage	500.00	500.00	0.00	0.00	500.00	100.00 %
<u>201-92-00-100-53241</u>	Printing & Promotions	1,500.00	1,500.00	0.00	241.69	1,258.31	83.89 %
<u>201-92-00-100-53301</u>	Dues & Memberships	2,900.00	2,900.00	0.00	814.50	2,085.50	71.91 %
<u>201-92-00-100-53401</u>	Electricity	38,000.00	38,000.00	0.00	14,430.15	23,569.85	62.03 %
<u>201-92-00-100-53411</u>	Gas	4,400.00	4,400.00	0.00	2,983.63	1,416.37	32.19 %
<u>201-92-00-100-53421</u>	Water	7,900.00	7,900.00	0.00	3,443.17	4,456.83	56.42 %
<u>201-92-00-100-53431</u>	Telephone	7,000.00	7,000.00	0.00	2,262.26	4,737.74	67.68 %
<u>201-92-00-100-53500</u>	Equipment Expense	1,700.00	1,700.00	0.00	125.47	1,574.53	92.62 %
<u>201-92-00-100-53563</u>	Elections	35,000.00	35,000.00	0.00	0.00	35,000.00	100.00 %
<u>201-92-00-100-53600</u>	Repair & Maintenance Services	1,500.00	1,500.00	0.00	375.00	1,125.00	75.00 %
<u>201-92-00-100-53644</u>	Computer Services	9,000.00	9,000.00	0.00	5,531.75	3,468.25	38.54 %
<u>201-92-00-100-53701</u>	Education and Training	3,400.00	3,400.00	0.00	1,470.00	1,930.00	56.76 %
<u>201-92-00-100-53711</u>	Meals & Travel	1,550.00	1,550.00	0.00	446.63	1,103.37	71.19 %
<u>201-92-00-100-53913</u>	General Liability Insurance	48,738.00	48,738.00	0.00	27,964.37	20,773.63	42.62 %
<u>201-92-00-100-53961</u>	Bank Charges	4,400.00	4,400.00	0.00	1,300.26	3,099.74	70.45 %
<u>201-92-00-100-53999</u>	Miscellaneous Contractual	144,000.00	144,000.00	5,016.18	31,238.37	112,761.63	78.31 %
<u>201-92-00-100-54500</u>	Recreational Programming	51,800.00	51,800.00	800.00	12,162.49	39,637.51	76.52 %
<u>201-92-00-100-55000</u>	Vehicle Expense	9,800.00	9,800.00	116.26	4,137.36	5,662.64	57.78 %
<u>201-92-00-100-57000</u>	Capital Expenditures	92,000.00	92,000.00	-687.00	46,400.39	45,599.61	49.56 %
<u>201-92-00-753-57000</u>	Capital Expenditures - LWCF	158,000.00	1,002,584.43	0.00	834,105.96	168,478.47	16.80 %
<u>201-92-00-754-57000</u>	Capital Expenditures - Omnibus (Su	1,985,000.00	2,008,427.54	0.00	0.00	2,008,427.54	100.00 %
<u>201-92-00-755-57000</u>	Capital Expenditures - Omnibus (Ke	980,000.00	986,382.74	0.00	0.00	986,382.74	100.00 %
	Expense Total:	4,533,870.59	5,408,265.30	33,219.27	1,544,754.48	3,863,510.82	71.44%
	Fund: 201 - PARKS & RECREATION Surplus (Deficit):	-245,742.59	-1,120,137.30	-31,426.32	-139,509.52	980,627.78	87.55%
	Report Surplus (Deficit):	-245,742.59	-1,120,137.30	-31,426.32	-139,509.52	980,627.78	87.55%

Budget Report

For Fiscal: 2024-2025 Period Ending: 06/30/2025

Group Summary

Account Type	Original	Current	Period	Fiscal	Variance	
	Total Budget	Total Budget	Activity	Activity	Favorable	Percent
					(Unfavorable)	Remaining
Fund: 201 - PARKS & RECREATION						
Revenue	4,288,128.00	4,288,128.00	1,792.95	1,405,244.96	-2,882,883.04	67.23%
Expense	4,533,870.59	5,408,265.30	33,219.27	1,544,754.48	3,863,510.82	71.44%
Fund: 201 - PARKS & RECREATION Surplus (Deficit):	-245,742.59	-1,120,137.30	-31,426.32	-139,509.52	980,627.78	87.55%
Report Surplus (Deficit):	-245,742.59	-1,120,137.30	-31,426.32	-139,509.52	980,627.78	87.55%

Budget Report

For Fiscal: 2024-2025 Period Ending: 06/30/2025

Fund Summary

Fund	Original	Current	Period	Fiscal	Variance
	Total Budget	Total Budget	Activity	Activity	Favorable
					(Unfavorable)
201 - PARKS & RECREATION	-245,742.59	-1,120,137.30	-31,426.32	-139,509.52	980,627.78
Report Surplus (Deficit):	-245,742.59	-1,120,137.30	-31,426.32	-139,509.52	980,627.78



City of Raytown, MO

Fund Balance Report

As Of 06/12/2025

Fund	Beginning Balance	Total Revenues	Total Expenses	Ending Balance
201 - PARKS & RECREATION	1,071,542.73	1,405,244.96	1,544,754.48	932,033.21
Report Total:	1,071,542.73	1,405,244.96	1,544,754.48	932,033.21

Raytown Main Street Association
June 2025
Robbie Tubbs

Jules will apply for a grant in July from the Missouri Main Street Association. This money will help standardize the facades downtown.

RMSA is applying for The T-Mobile Hometown Grant. T-Mobile funds community projects like revitalizing or repurposing historic structures, creating a downtown asset or destination or improving a space where friends and neighbors gather. The Pacemakers 2025 will award \$2,500 to fund costs including supplies needed for events. The Levitt Music Series Grant. The grant will award \$120,000 to a small community, with \$40,000 going for three different musical events.

RMSA is preparing to send out questionnaires to residents in order to finalize the Master Plan.

The new Main Street website will go live on June 25.

This year, tickets for the Senior Celebration will be available on-line, at Hy-Vee, or in the Chamber office.

Raytown Parks & Recreation Department
Director's Report
June 16, 2025

BOA – We had a yearly report about the Parks with the BOA on June 3, 2025 that went well.

Colman Park Disturbance- On Sunday June 1st and 1:30AM June 9th there were major disturbances in Colman Park. June 1st was a shelter group with a loud sound system disturbing the neighbors, with cars racing side by side from south to north on Lane Ave. I spent a big part of June 2nd speaking with park neighbors. One June 9th at 1:30AM 100+ cars pulled into the park and at 2:02AM gunfire started in the lower parking lot between shelter 1 and 2. Over 30 shots fired. Police drove through at 2:10AM. More Police arrived at 2:30AM to collect evidence.

53rd ST property LWCF – We still have not been able to complete our final report and reimbursement due to one check to the State of Missouri that was returned in the mail. That payment has to clear the bank before we can file for reimbursement. Parks staff are working extremely hard to get the property presentable for opening to the public. The grass inside the fences of the dog park is very patchy.

OMNIBUS - I have been contacted by HUD personnel that we have a new grant manager again for the fourth time. I believe that we are fully approved to start drawing down this \$3,000,000 grant award once our personnel access has been finalized.

George Butler & Associates – We met with Anthony Malone June 12th about our 53rd ST phase II and Kenagy Park projects regarding what we will need from the GBA engineers. We will have GBA post the RFP for the 53rd ST property, and then we will work out the Kenagy project bids, as they are not related well enough to be under one general contractor. The Section 3 hiring practices are something I have not had to include in bidding documents, so I would like to see the verbiage GBA uses in their bid documents before we send the Kenagy side out.

Little Blue Trace- The Little League group has ongoing minor issues with trash, field dragging, restrooms, and sports lighting etc. We are working with them as we have time. We also have a flag football group renting the soccer fields on the north side of the park who would like to run their reservation into the late fall.

Raytown 75th- I have been attending the event committee for the Raytown 75th anniversary events. Rice-Tremonti will host an event July 12th, We will host an evening ice cream social July 17th at Kenagy, and there will be another event July 19th at the Raytown High auditorium. These would be great times to campaign for the Parks Sales Tax.

TRIM Grant- MDC will let us expand our TRIM Grant to include parts of the right of way on Rock Island trail on Raytown Trafficway before the World Cup event. Tony has also specified other hazardous trees that need to be removed from the Parks and Rice-Tremonti properties.

Sales Tax Committee- The first meeting with the Sales Tax Committee was Tuesday May 13th, with Steve Meyers, Jason Sneddon, and Kat Hoffman. Toni Alexander also attended to be able to promote accurate information from the city side.

Sales Tax Revenue- June Sales Tax is \$34,570.02.



June 2025

PARK MAINTENANCE REPORT



Horticulture / Right of Way

Mole abatement at Little Blue is ongoing. Tulips are out and the annuals are going in the ground. We will be meeting with Chuck Conner to work on the next part of the 2025/2026 TRIM grant, as mentioned last month part of this will likely include replacing the trees at the 63rd street gateway, planting trees at Terry Copeland Park and along Raytown trafficway. We have had some additional hydro-seeding done at Terry Copeland Park and our staff have been seeding some areas and installed erosion mats so we can try to get a better stand of grass in some areas and get grass to grow in others. We are working on our Welcome to Raytown sign areas that have gotten overgrown with the spring rains. The tree at Minor Smith that has been shedding large limbs for weeks has finally given up completely and had to be removed. We removed a cherry tree from Rice Tremonti that was located near the Cellar.

Park Maintenance

The signs, benches, parking blocks, handicap parking signs, gate hinges, latches some painting and doggie pots have been installed and we have passed our final inspection. We still have some work to do to get the gates and latches modified to meet our desires to have auto closing and latching.

We built a drinking fountain for Minor Smith, and it has been installed. The new maverick has arrived and is in service, the ranger that the maverick replaced has been equipped to serve for maintenance and for events and the oldest ranger will be going to auction in the next couple of weeks.

Park trash has been exceptionally rough the last few weekends.

Raytown Parks & Recreation

Park Board Recreation Report

Submitted by: Matt Hartmann

Sports & Special Events Supervisor

June 16th, 2025

Fishing Derby

Overall, the event went very well. Despite the poor weather right before and immediately after, the weather held off during the derby. We ended up with 81 participants this year. Unfortunately, the fish were stocked too early and most had been caught and taken by the time the derby happened. Will stress harder next year how important it is to stock close to the date to the fishery.

Kids Day

Kids Day is next Thursday June 26th, we had to push it back a week due to the holiday falling on the 19th. Paramount Pony will return with the petting zoo and fire/PD both have fun demonstrations for the kids. The event will be from 10:00am to 1:00pm.

Spring Programs

As spring programming wraps up, I will do a deep dive on participants and have evaluations at the next board meeting.

Raytown Live Report

At the time of this writing, June show has not happened yet. I will have the report for this on Monday. Current budget revenue is \$10,700 versus expenses of \$10,750.

FRIENDS OF THE RICE-TREMONTI HOME ASSOCIATION

Minutes of May 21, 2025 Board Meeting

Began 6:08pm

Present: Christy Sewing-Pres/Acting Treas, Leigh Elmore-VP, Leesa Taylor-Rec Sec, Carla Coldwell, Aaron Smith, John McGuire, Barb Keogh, Brad Duncan and Diane Krizek. Quorum declared. **Guest:** Brit Slaughter-Henry was invited by Barb. She is an active member in the Chamber and is a 3-year Branch Manager for Community America in Raytown. Welcome, Brit! **CORRECTION OF APRIL MINUTES:** It was stated that the bell was going to be painted red but it was actually painted silver. Brad motioned and Barb seconded to approve the minutes. All in favor.

Treasurer's Report: April Balance Sheet- Rental property shows no amount for March nor April. However, both were paid by Woody's daughter before this meeting. **Events P&L: Tea Party-** wasn't as financially profitable as hoped but was still great community involvement and outreach. We received such positive feedback for future tea parties. Any ideas anyone may have would be welcome! **BBQ Fest-** So far, 25 vendors have paid \$1067.10 and still more vendors to come! **Continued Business:** Rental property is vacant as of May 5. Christy did a walk-thru and made a note to have any/all utilities shut off. There are some boxes of clothing that might go to good will and furniture/appliances that could be sold during our July yard sale. Christy was also requested to appear in a Zoom meeting with City officials of the Zoning Committee and Parks Dept on April 10. It appears Rice-Tremonti property is titled the Raytown City Parks and the Rental property is titled to the City of Raytown. Both properties are zoned "Highway Commercial"; the reason for our push to get this fire alarm system. Shayna, Codes official, argued that it shouldn't have been filed that way but as "Historical". Dept of Nat. Resources was contacted; they approve making a parking lot of the Rental property but must be gravel to keep historically aesthetic to the Rice-Tremonti property. City requires paved lots so the situation is straining. In short, Shayna said a re-survey must be done and combine both lots, rezoning will be easier to zone as "Historical". She also suggested we reach out to Mo Town regarding recommendations for contractors to make exterior repairs to the House.

Christy was asked to join a Parks Dept. Zoom meeting on May 19. She asked why, when there are 6 Raytown City parks; which we are one of and Parks Dept. pays for outside contractor for after-hours security every night to that this park isn't policed. His response was to get back to her with a quote. This is still under rebuttal. **Committee Reports: Grounds**-Rick Ledgerwood had an emergency and was unable to mow before the Boy Scouts Carnival but will have it mowed prior to marking the booth spaces. **Bell**: Girl Scouts camped Friday night, Brad and Boy Scouts removed the bell, dug up the old pole and concrete, replaced the poll and restored the bell including a fresh coat of silver paint. **Archeological Dig**: KU's Professor Kelly has contacted Dave Turner and they have worked out plan. She's also contacted Dept of Nat Resources to make sure all steps are made to begin a dig. We're in search of any known location of buildings previously on the property. **Building**: Leigh will reach out to Mo Town for contractors to repair/restore exterior of the House. **East Parlor**: Christy and Carla will begin renovations the start of June. **Events: BBQ Fest**-Carla needs all hands to help May 29 to treat the yard for ants and mark both spaces and May 30 to set up booth/tables for General Store and Ice Cream/Snow Cone. We have Tiffany's party bus to shuttle guests round trip from Sutherlands. **Treasures of the Past**- July 12. The July 17 Ice Cream Social has been moved to Kenagy Park. **New Business/Open Discussion**: After 2025, we will raise our vendor price to \$50 and may rise in the future. Our **State Business Registration** is due Aug 31. Leesa, as Rec Sec, was unanimously voted in favor to be the Registered Agent listed with our LLC. She and Christy have signed the proper form, scanned and uploaded to the website. A second **Tea Party** is up for discussion to have one during Christmas or an end-of-year event. It is suggested that our brochure be updated.

Ended 7:07pm Minutes taken by Leesa Taylor-Recording Secretary

Upcoming Events:

5/31 BBQ Fest 10a-5p 6/3 DAR Tour 10a 6/18 FORT Meeting

7/12 Treasures of the Past/Raytown's 75th Birthday/Yard Sale

7/16 FORT Meeting

Agenda item 1

Capital Expenditures for 2026

Options include:

1- Altec 70' boom lift- \$130,340

2- Mini-Excavator w/ attachments Auger and 30" flail mower- \$67,643.05

3- Remove and Replace playground at Kritser Park west- \$90,000

TEUPEN TC75A



FOR NEW EQUIPMENT SALES, CALL
800.958.2555
TO SPEAK WITH AN ALTEC REPRESENTATIVE
or visit us online at altec.com

 **Altec.**
TRACKED AERIALS

TEUPEN TC75A

SPECIFICATIONS

PERFORMANCE

Max Working Height	75 ft 5 in
Max Platform Height	68 ft 10 in
Horizontal Outreach with 441 lbs	36 ft 8 in
Max Up-and-Over Clearance	37 ft 9 in
Max Platform Capacity	441 lbs
Max Turntable Rotation	360°
Stabilization, Maximum Ground Slope	16.7° / 30.0 %
Height and Width Track Adjustment	9 / 1 ft 5 in
Gradeability, Max	16.7° / 30.0 %
Slope Angle, Max	15.5° / 27.0 %
Travel Speed	0.8 mph

WEIGHT*

Total Weight	6,592 lbs
Live Load in Traveling Position	84.0 psf
Live Load in Working Position	37.2 psf
Point load per outrigger plate, max.	5,036 lbf

POWER SOURCES

Combustion engine (Diesel)	Kubota Z602 (10.8 kW / 14.5 hp)
Fuel Tank Capacity (Diesel Engine)	3.17 gal

MEASUREMENTS*

Platform Height (A)	3 ft 7 in
Platform Length (B)	4 ft 7 in
Platform Width (C)	2 ft 3 in
Length, overall (D)	20 ft 4 in
Travel Height (F)	6 ft 5 in
Width, min. (G)	3 ft 2 in
Max Ground Clearance (H)	1 ft 3 in
Track (LxW) (I)	4 ft 9 in x 7 in
Stabilizer footprint both side wide (length) (J)	14 ft 10 in
Stabilizer footprint both side wide (width) (K)	14 ft 2 in
Stabilizer footprint one side narrow (length) (L)	19 ft 7 in
Stabilizer footprint one side narrow (width) (M)	11 ft 2 in
Stabilizer footprint both sides narrow (width) (N)	8 ft 5 in
Stabilizer plate Ø	7 in

POWER SUPPLY

Electric current, max.	115 V / 13 A
------------------------	--------------

* Weight and dimensions may vary depending on options and accessories

WORKING ENVELOPE

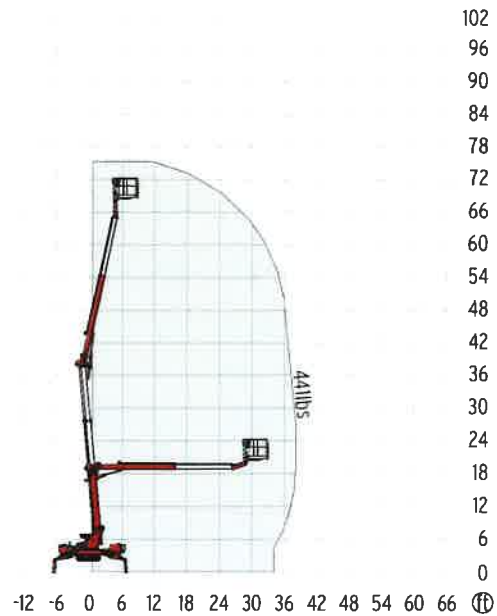
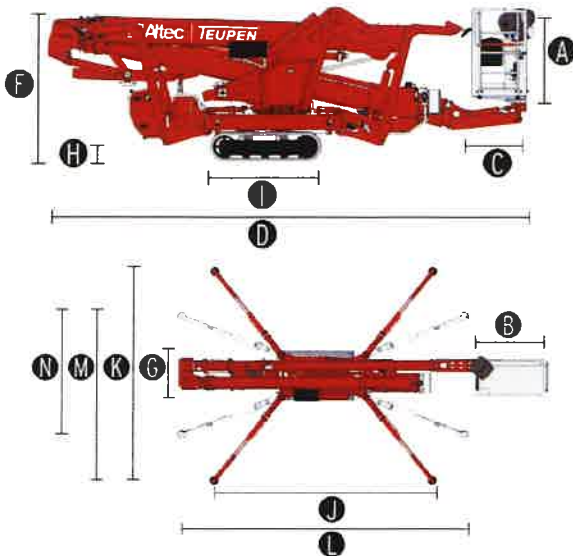

For more complete information on Altec products and services, visit us on the web at www.altec.com. Material and specifications are subject to change without notice. Featured units in photos may include optional features. Please contact an Altec representative for all available options. Altec® and the Altec logo are registered trademarks of Altec Inc. in the United States and various other countries and may not be used without permission.
© 2024 Altec Inc. All Rights Reserved. AI-OS-TEUPEN-TC75A-1014-v1-r1



NEW EQUIPMENT SALES | 800.958.2555 | SALES@ALTEC.COM | ALTEC.COM

Tony Mesa

From: Slade Screven <Slade.Screven@Altec.Com>
Sent: Monday, February 17, 2025 11:04 AM
To: Tony Mesa
Cc: Ben Crane
Subject: Altec Tuepen TC75
Attachments: TC75A-onesheet-web.pdf

Tony,

It was a pleasure speaking with you today. I have attached a spec sheet on the TC75 for your review. Your Altec account manager is Ben Crane. He will be in contact with you to answer any other questions you have and work on scheduling a demonstration for you.

The Sourcewell price on the TC75 is \$130,340.

Thanks again

Slade Screven
205 837 9926



Quotation Number: **JH956169**
 Quote Sent Date: **Jan 10, 2025**
 Expiration Date: **Feb 09, 2025**
 Prepared By: **Jim Hicks**
 Phone: 8163654669
 Email: jhicks@kcbobcat.com

Customer
RAYTOWN PARKS & RECR (290662) -
RAYTOWN - MO
 5912 LANE AVE
 RAYTOWN, MO, 64133-3751

Dealer
K.C. Bobcat, Blue Springs, MO
 1450 SE US 40 HWY
 BLUE SPRINGS, MO, 64014

Item Name	Item Number	Quantity	Price Each	Total
E35 25HP R2-Series Bobcat Compact Excavator	M3409	1	54,270.00	54,270.00
Serial number: B57919631				
Standard Equipment:				
24.8 HP			Hydraulic Joystick Controls	
Tier 4 Diesel Engine			Keyed Ignition	
Auto-Idle			LED Work Lights	
Auto-Shift, Two-Speed Travel			Lift Eye	
Auxiliary Hydraulics with Selectable Flow w/ Arm Mounted Flush Face Quick Couplers			Rubber Tracks	
Canopy			Spark Arrestor Exhaust System	
Includes: Cup Holder, Retractable Seat Belt, Vinyl Suspension Seat			Standard Arm	
Roll Over Protective Structure (ROPS)- Meets Requirements of ISO 12117-2: 2008			Standard Instrument Panel	
Tip Over Protective Structure (TOPS) - Meets Requirements of ISO 12117: 2000			Vandalism Protection	
Falling Object Protective Structure (FOPS) - Meets Requirements of ISO 10262:1998			X-Change Attachment Mounting System	
Control Console Locks			Telematics with 2-year Machine IQ Basics Subscription +90-Day Machine IQ Health & Security Trial	
Control Pattern Selector Valve (ISO/STD)			Warranty: 2 years, or 2000 hours whichever occurs first	
Dozer Blade with Float			Zero Tail Swing	
Engine/Hydraulic Monitor with Shutdown				
Fingertip Auxiliary Hydraulic Control				
Fingertip Boom Swing Control				
Horn				
Cab Deluxe Package	M3409-P11-C12	1	10,931.00	10,931.00
<i>Included:</i> Cab Deluxe Package:, Enclosed Cab with Auto HVAC, Telematics with 3-year Machine IQ Health & Security Subscription , Keyless Start, Bobcat 7" Touch Display with Radio and Bluetooth, Heated High Back Cloth Suspension Seat, Travel Motion Alarm				
Hydraulic Clamp - Long Arm - Class III w/ Diverter Valve	M3409-R08-C15	1	4,652.00	4,652.00
Hydraulic X-Change - Long Arm	M3409-R06-C04	1	2,458.00	2,458.00
Long Arm	M3409-R03-C02	1	1,786.00	1,786.00



Quotation Number: **JH956926**
 Quote Sent Date: **Jan 10, 2025**
 Expiration Date: **Feb 09, 2025**
 Prepared By: **Jim Hicks**
 Phone: 8163654669
 Email: jhicks@kcbobcat.com

Customer
RAYTOWN PARKS & RECR (290662) -
RAYTOWN - MO
 5912 LANE AVE
 RAYTOWN, MO, 64133-3751

Contact

Dealer
K.C. Bobcat, Blue Springs, MO
 1450 SE US 40 HWY
 BLUE SPRINGS, MO, 64014

Item Name	Item Number	Quantity	Price Each	Total
25PH Auger Drive Unit	7501036	1	2,409.00	2,409.00
Auger Mounting Frame Kit - X-Change	7507330	1	600.00	600.00
Auger Mounting Frame Kit - Bobtach	7508119	1	720.00	720.00
Total for 25PH Auger Drive Unit				3,729.00
30" Flail Mower	7225484	1	10,003.00	10,003.00
Case Drain E32 & E35	7245617	1	225.43	225.43
Flail Mower hoses (All Std Arm excavators) (E32 LA and E35 LA) and (E32, E35, E42, E45 and E48 ext arm) (All R2 E42/E48/E50/E60 arm configurations)	7245468	1	307.00	307.00
X-Change Mounting Cap (E32, E35, E42, E45, E48, E50, E55, E63)	7238337	1	1,183.00	1,183.00
Total for 30" Flail Mower				11,718.43
Quote Total - USD				15,447.43
Dealer P.D.I.				650.00
Destination Charges				458.00
Dealer Assembly Charges				525.00
Discount				
Sourcewell/Canoe Procurement Group Contract - #020223-CEC				-3,707.38
Sales total before Taxes				13,373.05
Taxes				0.00
Quote Total - USD				13,373.05

Customer acceptance:	
Quotation Number:: JH956926	Purchase Order: _____
Authorized Signature:	
Print: _____	Sign: _____